

PML MSH 10 Stereo Shotgun Condenser Microphone

The Pearl MS series has been setting the standards for on-location stereo recordings for 30+ years. The current range consists of the MSH 10, with a shotgun mid channel, and the cardioid MS 8CL - both offering outstanding audio quality in a lightweight, yet rugged design.

The MSH 10 has separate (i.e. non-matrixed) M and S channels, which gives the engineer greater control over the sound and the option to control the stereo image in post-production.

The Pearl 1930 shockmount is included and thanks to our collaboration with Rycote we can offer a range of high-quality accessories for even the most demanding recording conditions.

The MSH 10 is finished in a durable black powder coat paint. An LED indicates when phantom power is is on. Please note that the MSH 10 must be connected to a balanced input with 48 V Phantom power on both channels.



Wooden box



1930

Specification:

Output:	Hypercard./Bidirectional
Sensitivity	20 mV/Pa
Impedance	100 ohms
Operating voltage:	48 Volts
Rec. min. load imp:	1 Kohms
Current consumption:	8 mA
Self-noise:	16 dBA
Max SPL:	130 dB
Connector:	5-pin XLR
Dimensions:	Ø 28x186 mm
Weight:	160 grams

Other accessories:

Cable:	533/10
Windscreen:	Pearl 1730
Windscreen:	Rycote Pearl MS Pistol Grip Suspension

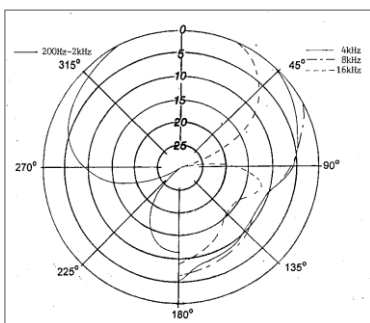

M

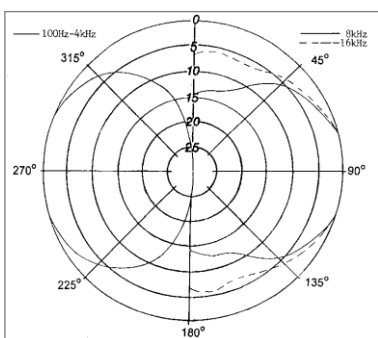
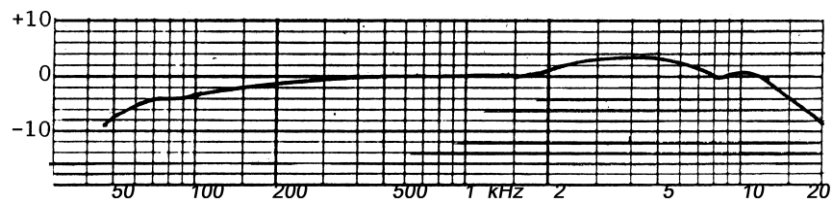

S

